



This notice of authorization must be conspicuously displayed at the site of work.

United States Army Corps of Engineers
Baltimore District

~~JUN 02 2010~~

A permit to construct a pier and dolphins.

at in the Anacostia River, Washington, DC.

has been issued to Florida Rock Properties, Inc. on ~~JUN 02 2010~~
P. Daniel Sullivan, Jr.

Address of Permittee 34 Loveton Circle, Ste. 100, Sparks, Maryland 21152

Permit Number

NAB-2009-01207-M07
FLORIDA ROCK/PIER & DOLPHINS

Kathy Anderson

KATHY B. ANDERSON
Chief, MB Section Southern

FOR THE District Commander



REPLY TO
ATTENTION OF

DEPARTMENT OF THE ARMY
BALTIMORE DISTRICT, U.S. ARMY CORPS OF ENGINEERS
P.O. BOX 1715
BALTIMORE, MD, 21203-1715

JUN 17 2010

JUN 02 2010

Operations Division

Florida Rock Properties, Inc.
Attn: Mr. P. Daniel Sullivan, Jr.
34 Loveton Circle, Suite 100
Sparks, Maryland 21152

Dear Mr. Sullivan:

This is in reference to your application for a Department of the Army (DA) permit, NAB-2009-01207-M07 (FLORIDA ROCK/PIER & DOLPHINS) dated April 30, 2009. Upon the recommendation of the Chief of Engineers and under the provisions of Section 10 of the Rivers and Harbors Act of 1899, you are hereby authorized by the Secretary of the Army to remove an existing deteriorated pier, mooring pilings, and dolphins; to construct a 10-foot wide by 137-foot long replacement pier; and to install 6 3-pile mooring dolphins to extend no more than 137 feet' channelward of the existing bulkhead in the Anacostia River at 25 Potomac Avenue, SE, Washington, DC. All work is to be accomplished in accordance with the enclosed plan(s).

Please note that on March 28, 2000, the final rule was established for an administrative appeal process for the Regulatory Program of the Corps of Engineers for approved jurisdictional determinations (JD), permit denials, and declined individual permits. Enclosed is a dated Notification of Applicant Options (NAO) fact sheet that explains the options that are available to you for your consideration when signing this permit.

You may accept this initial proffered letter of permission and your work is authorized. Your acceptance of this letter of permission means that you accept the permit in its entirety, and waive all rights to appeal the permit, including its terms and conditions, and approved jurisdictional determinations associated with the permit.

If you object to this letter of permission because of certain terms and conditions therein, including the approved JD associated with this permit, a letter outlining your objections to this initial proffered permit, including any additional information to clarify your objections, must be received by our District Engineer at the address below by August 2, 2010, or you will forfeit your right to appeal the permit in the future. The letter must be mailed to the following address:

Commander, Baltimore District
U.S. Army Corps of Engineers
Attn: CENAB-OP-R
P.O. Box 1715
Baltimore, Maryland 21203-1715

Please note that if you decline this initial proffered individual permit, you do not have a valid permit to conduct regulated activities in waters of the United States, and must not begin construction of the work requiring a Corps permit unless and until you receive and accept a valid Corps permit.

Enclosed is your NOTICE OF AUTHORIZATION, ENG FORM 4336, which must be conspicuously displayed at the site of the work. You are reminded that Corps' authorization does not obviate the need to obtain other required Federal, State, and or local permits and you should comply with the appropriate local critical area regulations prior to initiating the work.

This letter also contains an approved jurisdictional determination. Those areas indicated as waters of the United States, including jurisdictional wetlands shown within the "Area of Review" on the enclosed drawing dated May 14, 2009 are regulated by this office pursuant to Section 10 of the Rivers and Harbors Act of 1899. Enclosed is an Approved Jurisdictional Determination form that outlines the basis of our determination of jurisdiction over the "Area of Review" noted above. If you object to this determination, you may request an administrative appeal under Corps regulations at 33 CFR 331. If you request to appeal this determination, you must submit a completed RFA form to the North Atlantic Division Office at the following address:

Regulatory Appeals Review Officer
North Atlantic Division
U.S. Army Corps of Engineers
Fort Hamilton Military Community
General Lee Avenue, Building 301
Brooklyn, NY 11252-6700

In order for an RFA to be accepted by the Corps, the Corps must determine that it is complete; that it meets the criteria for appeal under 33 CFR Part 331.5, and that it has been received by the Division Office within 60 days of the date of the NAP. Should you decide to submit an RFA form, it must be received at the above address by August 2, 2010.

It is not necessary to submit an RFA form to the Division office if you do not object to the determination in this letter.

This approved jurisdictional determination associated with this permit is valid for five years from the date of this letter or until the Corps permit expiration date, whichever is less, unless new information warrants a revision before the expiration date, or a District Engineer has identified, after public notice and comment, that specific geographic areas with rapidly changing environmental conditions merit re-verification on a more frequent basis.

Enclosed is a compliance self-certification form. Upon completion of the authorized work and required mitigation, you are required to complete the enclosed compliance certification form and return it to the address indicated thereon.

A copy of this letter is also being forwarded to **District of Columbia Department of the Environment** for informational purposes. If you have any questions concerning this matter, please call Ms. Maria Teresi, of this office, at (410) 962-4501.

Sincerely,



Kathy B. Anderson
Chief, Maryland Section Southern

Enclosures

To identify how we can better serve you, we need your help. Please take the time to fill out our new customer service survey at: <http://www.nab.usace.army.mil/Regulatory/survey.htm>

DEPARTMENT OF THE ARMY PERMIT

Application Name and Permit Number: NAB-2009-01207-M07 (FLORIDA ROCK/PIER & DOLPHINS)

I. General Conditions:

A. The time limit for completing the work authorized ends on December 31, 2015. If you find that you need more time to complete the authorized activity, submit your request for a time extension to this office for consideration at least one month before the above date is reached.

B. You must maintain the activity authorized by this permit in good condition and in conformance with the terms and conditions of this permit. You are not relieved of this requirement if you abandon the permitted activity, although you may make a good faith transfer to a third party in compliance with General Condition 4 below. Should you wish to cease to maintain the authorized activity or should you desire to abandon it without a good faith transfer, you must obtain a modification of this permit from this office, which may require restoration of the area.

C. If you discover any previously unknown historic or archaeological remains while accomplishing the activity authorized by this permit, you must immediately notify this office of what you have found. We will initiate the Federal and state coordination required to determine if the remains warrant a recovery effort or if the site is eligible for listing in the National Register of Historic Places.

D. If you sell the property associated with this permit, you must obtain the signature of the new owner in the space provided and forward a copy of the permit to this office to validate the transfer of this authorization.

E. You must allow representatives from this office to inspect the authorized activity at any time deemed necessary to ensure that it is being or has been accomplished in accordance with the terms and conditions of your permit.

II. Special Conditions:

1. The permittee understands and agrees that, if future operations by the United States require the removal, relocation, or other alteration, of the structure or work herein authorized, or if, in the opinion of the Secretary of the Army or his authorized representative, said structure or work shall cause unreasonable obstruction to the free navigation of the navigable waters, the permittee will be required, upon due notice from the Corps of Engineers, to remove, relocate, or alter the structural work or obstructions caused thereby, without expense to the United States. No claim shall be made against the United States on account of any such removal or alteration.

2. You must install and maintain, at your expense, any safety lights and signals prescribed by the United States Coast Guard (USCG), through regulations or otherwise, on your authorized facilities. If the structures authorized by this permit are to be built in navigable waters, then you must contact the Commander (OAN), Fifth Coast Guard District, Federal Building, 431 Crawford Street, Portsmouth, Virginia, 23704, to ascertain the need for obstruction lights.

Your use of the permitted activity must not interfere with the public's right to free navigation on all navigable waters of the United States.

You must have a copy of this permit available on the vessel used for the authorized transportation and disposal of dredged material.

() You must advise this office in writing, at least two weeks before you start maintenance dredging activities under the authority of this permit.

() You must take the actions required to record this permit with the Registrar of Deeds or other appropriate official charged with the responsibility for maintaining records of titles to or interest in real property.

III. Further Information:

A. Congressional Authorities: You have been authorized to undertake the activity described above pursuant to:

- (X) Section 10 of the Rivers and Harbors Act of 1899 (33 U.S.C. 403).
- () Section 404 of the Clean Water Act (33 U.S.C. 1344).
- () Section 103 of the Marine Protection, Research and Sanctuaries Act of 1972 (33 U.S.C. 1413).

B. Limits of this authorization.

1. This permit does not obviate the need to obtain other Federal, state, or local authorizations required bylaw.
2. This permit does not grant any property rights or exclusive privileges.
3. This permit does not authorize any injury to the property or rights of others.
4. This permit does not authorize interference with any existing or proposed Federal projects.

C. Limits of Federal Liability. In issuing this permit, the Federal Government does not assume any liability for the following:

1. Damages to the permitted project or uses thereof as a result of other permitted or unpermitted activities or from natural causes.
2. Damages to the permitted project or uses thereof as a result of current or future activities undertaken by or on behalf of the United States in the public interest.
3. Damages to persons, property, or to other permitted or unpermitted activities or structures caused by the activity authorized by this permit.
4. Design or construction deficiencies associated with the permitted work.
5. Damage claims associated with any future modification, suspension, or revocation of this permit.

D. Reliance on Applicant's Data. The determination of this office that issuance of this permit is not contrary to the public interest was made in reliance on the information you provided.

E. Reevaluation of Permit Decision. This office may reevaluate its decision on this permit at any time the circumstances warrant. Circumstances that could require a reevaluation include, but are not limited to, the following:

1. You fail to comply with the terms and conditions of this permit.
2. The information provided by you in support of your permit application proves to have been false, incomplete, or inaccurate (see 4 above).
3. Significant new information surfaces which this office did not consider in reaching the original public interest decision.
4. Such a reevaluation may result in a determination that it is appropriate to use the suspension, modification, and revocation procedures contained in 33 CFR 325.7 or enforcement procedures such as those contained in 33 CFR 326.4 and 326.5. The referenced enforcement procedures provide for the issuance of an administrative order requiring you comply with the terms and conditions of your permit and for the initiation of legal action where appropriate. You will be required to pay for any corrective measures ordered by this office, and if you fail to comply with such directive, this office may in certain situations (such as those specified in 33 CFR 209.170) accomplish the corrective measures by contract or otherwise and bill you for the cost.

F. Extensions. General Condition 1 establishes a time limit for the completion of the activity authorized by this permit. Unless there are circumstances requiring either a prompt completion of the authorized activity or a reevaluation of the public interest decision, the Corps will normally give favorable consideration to a request for an extension of this time limit.

G. When the structures or work authorized by this permit are still in existence at the time the property is transferred, the terms and conditions of this permit will continue to be binding on the new owner(s) of the property. To validate the transfer of this permit and the associated liabilities associated with compliance with its terms and conditions, have the transferee write to the Regulatory Branch, U.S. Army Engineer District, P.O. Box 1715, Baltimore, Maryland 21203-1715.

When the structures or work authorized by this permit are still in existence at the time the property is transferred, the terms and conditions of this permit will continue to be binding on the new owner(s) of the property. To validate the transfer of this permit and the associated liabilities associated with compliance with its terms and conditions, have the transferee sign and date below.

TRANSFERREE

DATE



REPLY TO
ATTENTION OF

DEPARTMENT OF THE ARMY
BALTIMORE DISTRICT, U.S. ARMY CORPS OF ENGINEERS
P.O. BOX 1715
BALTIMORE, MD 21203-1715

SUBJECT: 2009-01207

Name of Permittee: FLORIDA ROCK PROPERTIES, INC. (P. Daniel Sullivan)

Date of Issuance: JUN 02 2010

Upon completion of the activity authorized by this permit and any mitigation required by the permit, sign this certification and return it to the following address:

US Army Corps of Engineers
Baltimore District
CENAB-OP-R
P.O. Box 1715
Baltimore, Maryland 21203-1715

Please note that your permitted activity is subject to compliance inspection by a U.S. Army Corps of Engineers representative. If you fail to comply with this permit, you are subject to permit suspension, modification, or revocation.

Please complete the following information:

1. Date authorized work commenced: _____ 2. Date authorized work completed: _____
3. Was all work and any required mitigation, completed in accordance with your permit authorization, including all general and/or specific conditions? YES ___ NO ___
4. Explain in detail any deviations to the authorized work and/or mitigation (use additional sheets if necessary)

5. Wetland Mitigation: Required? YES ___ NO ___ Required Completion Date _____
Completed? YES ___ NO ___ Mitigation Monitoring Reports Required? YES ___ NO ___
6. Attach labeled photographs showing completed work including mitigation area(s).

I hereby certify that the work authorized by the above referenced permit has been completed in accordance with the terms and conditions of the said permit, and required mitigation was completed in accordance with the permit conditions.

Signature of Permittee

Date

APPROVED JURISDICTIONAL DETERMINATION FORM
U.S. Army Corps of Engineers

This form should be completed by following the instructions provided in Section IV of the JD Form Instructional Guidebook.

SECTION I: BACKGROUND INFORMATION

A. REPORT COMPLETION DATE FOR APPROVED JURISDICTIONAL DETERMINATION (JD): JUN 02 2010

B. DISTRICT OFFICE, FILE NAME, AND NUMBER: 2009-01207-M07 (FLORIDA ROCK/PIER W/MOORING CLUSTERS)

C. PROJECT LOCATION AND BACKGROUND INFORMATION: Project is located within the Anacostia River. The pier, mooring piles, and dolphin structures exist but have deteriorated to an unusable condition and are being replaced

State: District of Columbia County/parish/borough: City: Washington

Center coordinates of site (lat/long in degree decimal format): Lat. 38.87165° N, Long. -77.00678° W

Universal Transverse Mercator:

Name of nearest waterbody: Anacostia River

Name of nearest Traditional Navigable Water (TNW) into which the aquatic resource flows: Anacostia River

Name of watershed or Hydrologic Unit Code (HUC): 02070010.

Check if map/diagram of review area and/or potential jurisdictional areas is/are available upon request.

Check if other sites (e.g., offsite mitigation sites, disposal sites, etc...) are associated with this action and are recorded on a different JD form.

D. REVIEW PERFORMED FOR SITE EVALUATION (CHECK ALL THAT APPLY):

Office (Desk) Determination. Date: May 18, 2010

Field Determination. Date(s):

SECTION II: SUMMARY OF FINDINGS

A. RHA SECTION 10 DETERMINATION OF JURISDICTION.

There ~~are~~ are "navigable waters of the U.S." within Rivers and Harbors Act (RHA) jurisdiction (as defined by 33 CFR part 329) in the review area. [Required]

Waters subject to the ebb and flow of the tide.

Waters are presently used, or have been used in the past, or may be susceptible for use to transport interstate or foreign commerce.

Explain: The Anacostia River flows in Washington D.C. and Montgomery County Maryland.

B. CWA SECTION 404 DETERMINATION OF JURISDICTION.

There ~~are~~ are "waters of the U.S." within Clean Water Act (CWA) jurisdiction (as defined by 33 CFR part 328) in the review area. [Required]

1. Waters of the U.S.

a. Indicate presence of waters of U.S. in review area (check all that apply):¹

TNWs, including territorial seas

Wetlands adjacent to TNWs

Relatively permanent waters² (RPWs) that flow directly or indirectly into TNWs

Non-RPWs that flow directly or indirectly into TNWs

Wetlands directly abutting RPWs that flow directly or indirectly into TNWs

Wetlands adjacent to but not directly abutting RPWs that flow directly or indirectly into TNWs

Wetlands adjacent to non-RPWs that flow directly or indirectly into TNWs

Impoundments of jurisdictional waters

Isolated (interstate or intrastate) waters, including isolated wetlands

b. Identify (estimate) size of waters of the U.S. in the review area:

Non-wetland waters: 137 linear feet: 10 width (ft) and/or acres.

Wetlands: acres.

c. Limits (boundaries) of jurisdiction based on: ~~Established by mean (average) high waters~~

Elevation of established OHWM (if known):

2. Non-regulated waters/wetlands (check if applicable):³

Potentially jurisdictional waters and/or wetlands were assessed within the review area and determined to be not jurisdictional.

Explain:

¹ Boxes checked below shall be supported by completing the appropriate sections in Section III below.

² For purposes of this form, an RPW is defined as a tributary that is not a TNW and that typically flows year-round or has continuous flow at least "seasonally" (e.g., typically 3 months).

³ Supporting documentation is presented in Section III.F.

SECTION III: CWA ANALYSIS

A. TNWs AND WETLANDS ADJACENT TO TNWs

The agencies will assert jurisdiction over TNWs and wetlands adjacent to TNWs. If the aquatic resource is a TNW, complete Section III.A.1 and Section III.D.1. only; if the aquatic resource is a wetland adjacent to a TNW, complete Sections III.A.1 and 2 and Section III.D.1.; otherwise, see Section III.B below.

1. TNW

Identify TNW: Anacostia River.

Summarize rationale supporting determination: The Anacostia River is subjected to the ebb and flow of the tide and is used as part of interstate comerance. There is a federal channel currently being maintained by the U. S. Army Corps of Engineers.

2. Wetland adjacent to TNW

Summarize rationale supporting conclusion that wetland is "adjacent":

B. CHARACTERISTICS OF TRIBUTARY (THAT IS NOT A TNW) AND ITS ADJACENT WETLANDS (IF ANY):

This section summarizes information regarding characteristics of the tributary and its adjacent wetlands, if any, and it helps determine whether or not the standards for jurisdiction established under *Rapanos* have been met.

The agencies will assert jurisdiction over non-navigable tributaries of TNWs where the tributaries are "relatively permanent waters" (RPWs), i.e. tributaries that typically flow year-round or have continuous flow at least seasonally (e.g., typically 3 months). A wetland that directly abuts an RPW is also jurisdictional. If the aquatic resource is not a TNW, but has year-round (perennial) flow, skip to Section III.D.2. If the aquatic resource is a wetland directly abutting a tributary with perennial flow, skip to Section III.D.4.

A wetland that is adjacent to but that does not directly abut an RPW requires a significant nexus evaluation. Corps districts and EPA regions will include in the record any available information that documents the existence of a significant nexus between a relatively permanent tributary that is not perennial (and its adjacent wetlands if any) and a traditional navigable water, even though a significant nexus finding is not required as a matter of law.

If the waterbody⁴ is not an RPW, or a wetland directly abutting an RPW, a JD will require additional data to determine if the waterbody has a significant nexus with a TNW. If the tributary has adjacent wetlands, the significant nexus evaluation must consider the tributary in combination with all of its adjacent wetlands. This significant nexus evaluation that combines, for analytical purposes, the tributary and all of its adjacent wetlands is used whether the review area identified in the JD request is the tributary, or its adjacent wetlands, or both. If the JD covers a tributary with adjacent wetlands, complete Section III.B.1 for the tributary, Section III.B.2 for any onsite wetlands, and Section III.B.3 for all wetlands adjacent to that tributary, both onsite and offsite. The determination whether a significant nexus exists is determined in Section III.C below.

1. Characteristics of non-TNWs that flow directly or indirectly into TNW

(i) General Area Conditions:

Watershed size: Pick List
Drainage area: Pick List
Average annual rainfall: _____ inches
Average annual snowfall: _____ inches

(ii) Physical Characteristics:

(a) Relationship with TNW:

- Tributary flows directly into TNW.
 Tributary flows through Pick List tributaries before entering TNW.

Project waters are Pick List river miles from TNW.
Project waters are Pick List river miles from RPW.
Project waters are Pick List aerial (straight) miles from TNW.
Project waters are Pick List aerial (straight) miles from RPW.
Project waters cross or serve as state boundaries. Explain:

Identify flow route to TNW⁵:

⁴ Note that the Instructional Guidebook contains additional information regarding swales, ditches, washes, and erosional features generally and in the arid West.

⁵ Flow route can be described by identifying, e.g., tributary a, which flows through the review area, to flow into tributary b, which then flows into TNW.

Tributary stream order, if known:

(b) General Tributary Characteristics (check all that apply):

- Tributary is: Natural
 Artificial (man-made). Explain:
 Manipulated (man-altered). Explain:

Tributary properties with respect to top of bank (estimate):

Average width: feet
Average depth: feet
Average side slopes: Pick List

Primary tributary substrate composition (check all that apply):

- | | | |
|--|--|-----------------------------------|
| <input type="checkbox"/> Silts | <input type="checkbox"/> Sands | <input type="checkbox"/> Concrete |
| <input type="checkbox"/> Cobbles | <input type="checkbox"/> Gravel | <input type="checkbox"/> Muck |
| <input type="checkbox"/> Bedrock | <input type="checkbox"/> Vegetation. Type/% cover: | |
| <input type="checkbox"/> Other. Explain: | | |

Tributary condition/stability [e.g., highly eroding, sloughing banks]. Explain:

Presence of run/riffle/pool complexes. Explain:

Tributary geometry: Pick List

Tributary gradient (approximate average slope): %

(c) Flow:

Tributary provides for: Pick List

Estimate average number of flow events in review area/year: Pick List

Describe flow regime:

Other information on duration and volume:

Surface flow is: Pick List. Characteristics:

Subsurface flow: Pick List. Explain findings:

- Dye (or other) test performed:

Tributary has (check all that apply):

- | | |
|---|---|
| <input type="checkbox"/> Bed and banks | |
| <input type="checkbox"/> OHWM ⁶ (check all indicators that apply): | |
| <input type="checkbox"/> clear, natural line impressed on the bank | <input type="checkbox"/> the presence of litter and debris |
| <input type="checkbox"/> changes in the character of soil | <input type="checkbox"/> destruction of terrestrial vegetation |
| <input type="checkbox"/> shelving | <input type="checkbox"/> the presence of wrack line |
| <input type="checkbox"/> vegetation matted down, bent, or absent | <input type="checkbox"/> sediment sorting |
| <input type="checkbox"/> leaf litter disturbed or washed away | <input type="checkbox"/> scour |
| <input type="checkbox"/> sediment deposition | <input type="checkbox"/> multiple observed or predicted flow events |
| <input type="checkbox"/> water staining | <input type="checkbox"/> abrupt change in plant community |
| <input type="checkbox"/> other (list): | |
| <input type="checkbox"/> Discontinuous OHWM. ⁷ Explain: | |

If factors other than the OHWM were used to determine lateral extent of CWA jurisdiction (check all that apply):

- | | |
|--|--|
| <input checked="" type="checkbox"/> High Tide Line indicated by: | <input checked="" type="checkbox"/> Mean High Water Mark indicated by: |
| <input type="checkbox"/> oil or scum line along shore objects | <input type="checkbox"/> survey to available datum; |
| <input type="checkbox"/> fine shell or debris deposits (foreshore) | <input type="checkbox"/> physical markings; |
| <input type="checkbox"/> physical markings/characteristics | <input type="checkbox"/> vegetation lines/changes in vegetation types. |
| <input type="checkbox"/> tidal gauges | |
| <input type="checkbox"/> other (list): | |

(iii) Chemical Characteristics:

Characterize tributary (e.g., water color is clear, discolored, oily film; water quality; general watershed characteristics, etc.).

Explain:

Identify specific pollutants, if known:

⁶A natural or man-made discontinuity in the OHWM does not necessarily sever jurisdiction (e.g., where the stream temporarily flows underground, or where the OHWM has been removed by development or agricultural practices). Where there is a break in the OHWM that is unrelated to the waterbody's flow regime (e.g., flow over a rock outcrop or through a culvert), the agencies will look for indicators of flow above and below the break.

⁷Ibid.

(iv) **Biological Characteristics. Channel supports (check all that apply):**

- Riparian corridor. Characteristics (type, average width):
- Wetland fringe. Characteristics:
- Habitat for:
 - Federally Listed species. Explain findings:
 - Fish/spawn areas. Explain findings:
 - Other environmentally-sensitive species. Explain findings:
 - Aquatic/wildlife diversity. Explain findings:

2. **Characteristics of wetlands adjacent to non-TNW that flow directly or indirectly into TNW**

(i) **Physical Characteristics:**

(a) General Wetland Characteristics:

Properties:

Wetland size: acres

Wetland type. Explain:

Wetland quality. Explain:

Project wetlands cross or serve as state boundaries. Explain:

(b) General Flow Relationship with Non-TNW:

Flow is: Pick List. Explain:

Surface flow is: Pick List

Characteristics:

Subsurface flow: Pick List. Explain findings:

- Dye (or other) test performed:

(c) Wetland Adjacency Determination with Non-TNW:

Directly abutting

Not directly abutting

Discrete wetland hydrologic connection. Explain:

Ecological connection. Explain:

Separated by berm/barrier. Explain:

(d) Proximity (Relationship) to TNW

Project wetlands are Pick List river miles from TNW.

Project waters are Pick List aerial (straight) miles from TNW.

Flow is from: Pick List.

Estimate approximate location of wetland as within the Pick List floodplain.

(ii) **Chemical Characteristics:**

Characterize wetland system (e.g., water color is clear, brown, oil film on surface; water quality; general watershed characteristics; etc.). Explain:

Identify specific pollutants, if known:

(iii) **Biological Characteristics. Wetland supports (check all that apply):**

- Riparian buffer. Characteristics (type, average width):
- Vegetation type/percent cover. Explain:
- Habitat for:
 - Federally Listed species. Explain findings:
 - Fish/spawn areas. Explain findings:
 - Other environmentally-sensitive species. Explain findings:
 - Aquatic/wildlife diversity. Explain findings:

3. **Characteristics of all wetlands adjacent to the tributary (if any)**

All wetland(s) being considered in the cumulative analysis: Pick List

Approximately () acres in total are being considered in the cumulative analysis.

For each wetland, specify the following:

Directly abuts? (Y/N)

Size (in acres)

Directly abuts? (Y/N)

Size (in acres)

Summarize overall biological, chemical and physical functions being performed:

C. SIGNIFICANT NEXUS DETERMINATION

A significant nexus analysis will assess the flow characteristics and functions of the tributary itself and the functions performed by any wetlands adjacent to the tributary to determine if they significantly affect the chemical, physical, and biological integrity of a TNW. For each of the following situations, a significant nexus exists if the tributary, in combination with all of its adjacent wetlands, has more than a speculative or insubstantial effect on the chemical, physical and/or biological integrity of a TNW. Considerations when evaluating significant nexus include, but are not limited to the volume, duration, and frequency of the flow of water in the tributary and its proximity to a TNW, and the functions performed by the tributary and all its adjacent wetlands. It is not appropriate to determine significant nexus based solely on any specific threshold of distance (e.g. between a tributary and its adjacent wetland or between a tributary and the TNW). Similarly, the fact an adjacent wetland lies within or outside of a floodplain is not solely determinative of significant nexus.

Draw connections between the features documented and the effects on the TNW, as identified in the *Rapanos* Guidance and discussed in the Instructional Guidebook. Factors to consider include, for example:

- Does the tributary, in combination with its adjacent wetlands (if any), have the capacity to carry pollutants or flood waters to TNWs, or to reduce the amount of pollutants or flood waters reaching a TNW?
- Does the tributary, in combination with its adjacent wetlands (if any), provide habitat and lifecycle support functions for fish and other species, such as feeding, nesting, spawning, or rearing young for species that are present in the TNW?
- Does the tributary, in combination with its adjacent wetlands (if any), have the capacity to transfer nutrients and organic carbon that support downstream foodwebs?
- Does the tributary, in combination with its adjacent wetlands (if any), have other relationships to the physical, chemical, or biological integrity of the TNW?

Note: the above list of considerations is not inclusive and other functions observed or known to occur should be documented below:

1. Significant nexus findings for non-RPW that has no adjacent wetlands and flows directly or indirectly into TNWs. Explain findings of presence or absence of significant nexus below, based on the tributary itself, then go to Section III.D:
2. Significant nexus findings for non-RPW and its adjacent wetlands, where the non-RPW flows directly or indirectly into TNWs. Explain findings of presence or absence of significant nexus below, based on the tributary in combination with all of its adjacent wetlands, then go to Section III.D:
3. Significant nexus findings for wetlands adjacent to an RPW but that do not directly abut the RPW. Explain findings of presence or absence of significant nexus below, based on the tributary in combination with all of its adjacent wetlands, then go to Section III.D:

D. DETERMINATIONS OF JURISDICTIONAL FINDINGS. THE SUBJECT WATERS/WETLANDS ARE (CHECK ALL THAT APPLY):

1. TNWs and Adjacent Wetlands. Check all that apply and provide size estimates in review area:
 TNWs: 137 linear feet 10 width (ft), Or, acres.
 Wetlands adjacent to TNWs: acres.
2. RPWs that flow directly or indirectly into TNWs.
 Tributaries of TNWs where tributaries typically flow year-round are jurisdictional. Provide data and rationale indicating that tributary is perennial:
 Tributaries of TNW where tributaries have continuous flow "seasonally" (e.g., typically three months each year) are jurisdictional. Data supporting this conclusion is provided at Section III.B. Provide rationale indicating that tributary flows seasonally:

Provide estimates for jurisdictional waters in the review area (check all that apply):

Tributary waters: linear feet width (ft).

Other non-wetland waters: acres.

Identify type(s) of waters:

3. Non-RPWs⁸ that flow directly or indirectly into TNWs.

- Waterbody that is not a TNW or an RPW, but flows directly or indirectly into a TNW, and it has a significant nexus with a TNW is jurisdictional. Data supporting this conclusion is provided at Section III.C.

Provide estimates for jurisdictional waters within the review area (check all that apply):

Tributary waters: linear feet width (ft).

Other non-wetland waters: acres.

Identify type(s) of waters:

4. Wetlands directly abutting an RPW that flow directly or indirectly into TNWs.

- Wetlands directly abut RPW and thus are jurisdictional as adjacent wetlands.
- Wetlands directly abutting an RPW where tributaries typically flow year-round. Provide data and rationale indicating that tributary is perennial in Section III.D.2, above. Provide rationale indicating that wetland is directly abutting an RPW:

- Wetlands directly abutting an RPW where tributaries typically flow "seasonally." Provide data indicating that tributary is seasonal in Section III.B and rationale in Section III.D.2, above. Provide rationale indicating that wetland is directly abutting an RPW:

Provide acreage estimates for jurisdictional wetlands in the review area: acres.

5. Wetlands adjacent to but not directly abutting an RPW that flow directly or indirectly into TNWs.

- Wetlands that do not directly abut an RPW, but when considered in combination with the tributary to which they are adjacent and with similarly situated adjacent wetlands, have a significant nexus with a TNW are jurisdictional. Data supporting this conclusion is provided at Section III.C.

Provide acreage estimates for jurisdictional wetlands in the review area: acres.

6. Wetlands adjacent to non-RPWs that flow directly or indirectly into TNWs.

- Wetlands adjacent to such waters, and have when considered in combination with the tributary to which they are adjacent and with similarly situated adjacent wetlands, have a significant nexus with a TNW are jurisdictional. Data supporting this conclusion is provided at Section III.C.

Provide estimates for jurisdictional wetlands in the review area: acres.

7. Impoundments of jurisdictional waters.⁹

As a general rule, the impoundment of a jurisdictional tributary remains jurisdictional.

- Demonstrate that impoundment was created from "waters of the U.S.," or
- Demonstrate that water meets the criteria for one of the categories presented above (1-6), or
- Demonstrate that water is isolated with a nexus to commerce (see E below).

E. ISOLATED [INTERSTATE OR INTRA-STATE] WATERS, INCLUDING ISOLATED WETLANDS, THE USE, DEGRADATION OR DESTRUCTION OF WHICH COULD AFFECT INTERSTATE COMMERCE, INCLUDING ANY SUCH WATERS (CHECK ALL THAT APPLY):¹⁰

- which are or could be used by interstate or foreign travelers for recreational or other purposes.
- from which fish or shellfish are or could be taken and sold in interstate or foreign commerce.
- which are or could be used for industrial purposes by industries in interstate commerce.
- Interstate isolated waters. Explain:
- Other factors. Explain:

Identify water body and summarize rationale supporting determination:

⁸See Footnote # 3.

⁹To complete the analysis refer to the key in Section III.D.6 of the Instructional Guidebook.

¹⁰Prior to asserting or declining CWA jurisdiction based solely on this category, Corps Districts will elevate the action to Corps and EPA HQ for review consistent with the process described in the Corps/EPA Memorandum Regarding CWA Act Jurisdiction Following Rapanos.

Provide estimates for jurisdictional waters in the review area (check all that apply):

Tributary waters: linear feet width (ft).

Other non-wetland waters: acres.

Identify type(s) of waters:

Wetlands: acres.

F. NON-JURISDICTIONAL WATERS, INCLUDING WETLANDS (CHECK ALL THAT APPLY):

If potential wetlands were assessed within the review area, these areas did not meet the criteria in the 1987 Corps of Engineers Wetland Delineation Manual and/or appropriate Regional Supplements.

Review area included isolated waters with no substantial nexus to interstate (or foreign) commerce.

Prior to the Jan 2001 Supreme Court decision in "SWANCC," the review area would have been regulated based solely on the "Migratory Bird Rule" (MBR).

Waters do not meet the "Significant Nexus" standard, where such a finding is required for jurisdiction. Explain:

Other: (explain, if not covered above):

Provide acreage estimates for non-jurisdictional waters in the review area, where the sole potential basis of jurisdiction is the MBR factors (i.e., presence of migratory birds, presence of endangered species, use of water for irrigated agriculture), using best professional judgment (check all that apply):

Non-wetland waters (i.e., rivers, streams): linear feet width (ft).

Lakes/ponds: acres.

Other non-wetland waters: acres. List type of aquatic resource:

Wetlands: acres.

Provide acreage estimates for non-jurisdictional waters in the review area that do not meet the "Significant Nexus" standard, where such a finding is required for jurisdiction (check all that apply):

Non-wetland waters (i.e., rivers, streams): linear feet, width (ft).

Lakes/ponds: acres.

Other non-wetland waters: acres. List type of aquatic resource:

Wetlands: acres.

SECTION IV: DATA SOURCES.

A. SUPPORTING DATA. Data reviewed for JD (check all that apply - checked items shall be included in case file and, where checked and requested, appropriately reference sources below):

Maps, plans, plots or plat submitted by or on behalf of the applicant/consultant: Submitted by Moffatt & Nichol on behalf of the Applicant- Florida Rock Properties dated 30 April 2009.

Data sheets prepared/submitted by or on behalf of the applicant/consultant.

Office concurs with data sheets/delineation report.

Office does not concur with data sheets/delineation report.

Data sheets prepared by the Corps:

Corps navigable waters' study:

U.S. Geological Survey Hydrologic Atlas:

USGS NHD data.

USGS 8 and 12 digit HUC maps.

U.S. Geological Survey map(s). Cite scale & quad name:

USDA Natural Resources Conservation Service Soil Survey. Citation:

National wetlands inventory map(s). Cite name:

State/Local wetland inventory map(s):

FEMA/FIRM maps:

100-year Floodplain Elevation is: (National Geodetic Vertical Datum of 1929)

Photographs: Aerial (Name & Date):

or Other (Name & Date): Personal site photographs of the area throughout the years submitted by the consultant

Moffatt & Nichol on behalf of the Applicant- Florida Rock Properties.

Previous determination(s). File no. and date of response letter:

Applicable/supporting case law:

Applicable/supporting scientific literature:

Other information (please specify):

B. ADDITIONAL COMMENTS TO SUPPORT JD:

**NOTIFICATION OF ADMINISTRATIVE APPEAL OPTIONS AND PROCESS AND
REQUEST FOR APPEAL (NAO/NAP fact sheet & RFA form)**

Applicant: Florida Rock/Pier W/Mooring Clusters		File Number: 2009-01207	Date: JUN 02 2010
Attached is:		See Section below	
X	INITIAL PROFFERED PERMIT (Standard Permit or Letter of permission)	A	
	PROFFERED PERMIT (Standard Permit or Letter of permission)	B	
	PERMIT DENIAL	C	
X	APPROVED JURISDICTIONAL DETERMINATION	D	
	PRELIMINARY JURISDICTIONAL DETERMINATION	E	

SECTION I - The following identifies your rights and options regarding an administrative appeal of the above decision. Additional information may be found at <http://usace.army.mil/inet/functions/cw/cecwo/reg/or> Corps regulations at 33 CFR Part 331.

A: INITIAL PROFFERED PERMIT: You may accept or object to the permit.

- **ACCEPT:** If you received a Standard Permit, you may sign the permit document and return it to the Baltimore District Engineer for final authorization. If you received a Letter of Permission (LOP), you may accept the LOP and your work is authorized. Your signature on the Standard Permit or acceptance of the LOP means that you accept the permit in its entirety, and waive all rights to appeal the permit, including its terms and conditions, and approved jurisdictional determinations (JD) associated with the permit.
- **OBJECT:** If you object to the permit (Standard or LOP) because of certain terms and conditions therein, you may request that the permit be modified accordingly. You must complete Section II of this form and return the form to the Baltimore District Engineer. Your objections must be received by the Baltimore District Engineer within 60 days of the date of this notice, or you will forfeit your right to appeal the permit in the future. Upon receipt of your letter, the Baltimore District Engineer will evaluate your objections and may: (a) modify the permit to address all of your concerns, (b) modify the permit to address some of your objections, or (c) not modify the permit having determined that the permit should be issued as previously written. After evaluating your objections, the Baltimore District Engineer will send you a proffered permit for your reconsideration, as indicated in Section B below.

B: PROFFERED PERMIT: You may accept or appeal the permit

- **ACCEPT:** If you received a Standard Permit, you may sign the permit document and return it to the Baltimore District Engineer for final authorization. If you received a Letter of Permission (LOP), you may accept the LOP and your work is authorized. Your signature on the Standard Permit or acceptance of the LOP means that you accept the permit in its entirety, and waive all rights to appeal the permit, including its terms and conditions, and approved jurisdictional determinations associated with the permit.
- **APPEAL:** If you choose to decline the proffered permit (Standard or LOP) because of certain terms and conditions therein, you may appeal the declined permit under the Corps of Engineers Administrative Appeal Process by completing Section II of this form and sending the form to the North Atlantic Division Engineer, ATTN: CENAD-PD-PSD-O, Fort Hamilton Military Community, Building 301, General Lee Avenue, Brooklyn, NY 11252-6700. This form must be received by the North Atlantic Division Engineer within 60 days of the date of this notice with a copy furnished to the Baltimore District Engineer.

C: PERMIT DENIAL: You may appeal the denial of a permit under the Corps of Engineers Administrative Appeal Process by completing Section II of this form and sending the form to the North Atlantic Division Engineer, ATTN: CENAD-PD-PSD-O, Fort Hamilton Military Community, Building 301, General Lee Avenue, Brooklyn, NY 11252-6700. This form must be received by the North Atlantic Division Engineer within 60 days of the date of this notice with a copy furnished to the Baltimore District Engineer.

D: APPROVED JURISDICTIONAL DETERMINATION: You may accept or appeal the approved JD or provide new information.

- **ACCEPT:** You do not need to notify the Corps to accept an approved JD. Failure to notify the Corps within 60 days of the date of this notice, means that you accept the approved JD in its entirety, and waive all rights to appeal the approved JD.
- **APPEAL:** If you disagree with the approved JD, you may appeal the approved JD under the Corps of Engineers Administrative Appeal Process by completing Section II of this form and sending the form to the North Atlantic Division Engineer, ATTN: CENAD-PD-PSD-O, Fort Hamilton Military Community, Building 301, General Lee Avenue, Brooklyn, NY 11252-6700. This form must be received by the North Atlantic Division Engineer within 60 days of the date of this notice with a copy furnished to the Baltimore District Engineer.

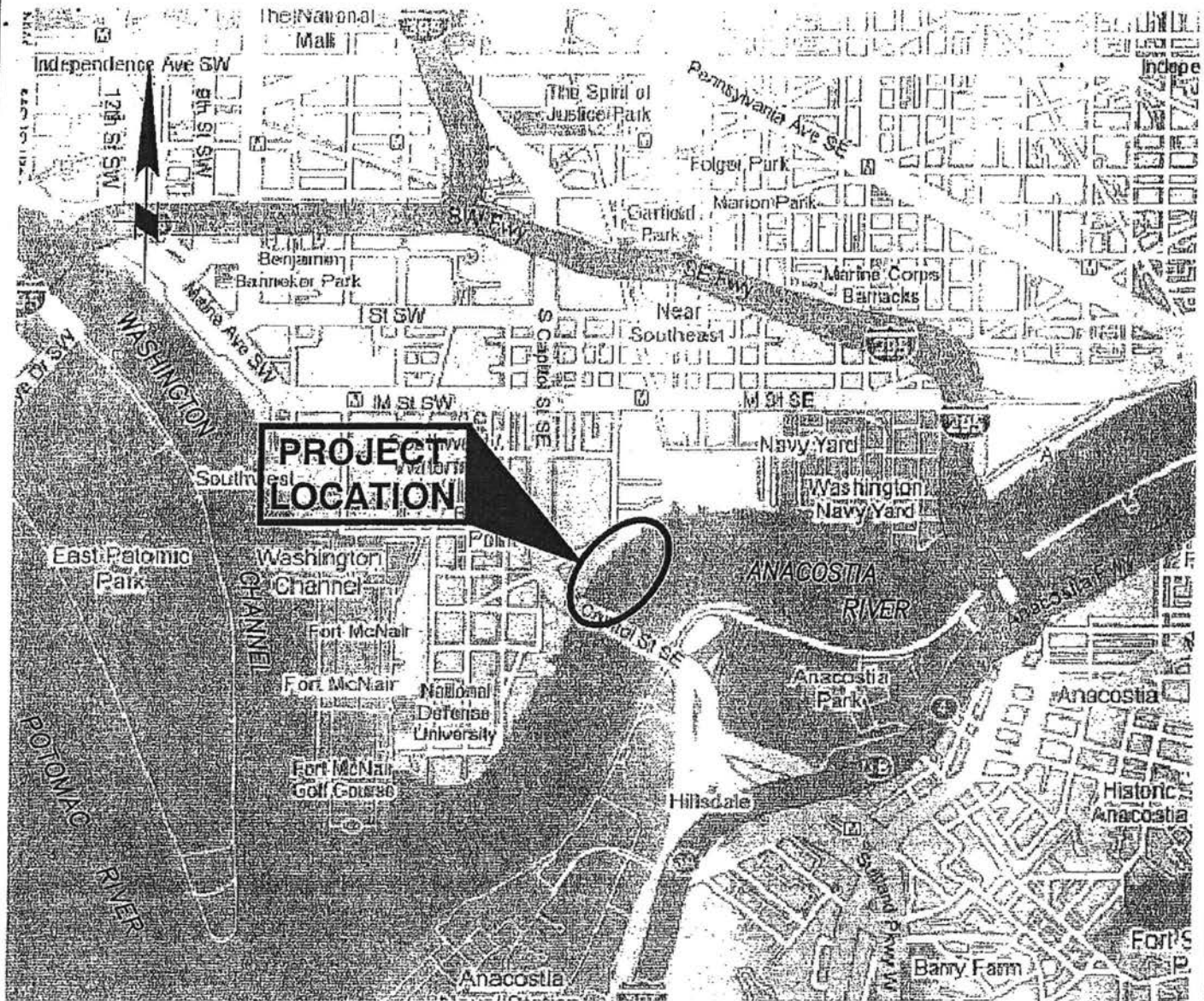

VICINITY MAP

N.T.S.

SUMMARY OF PROPOSED CONSTRUCTION:

1. EX. PIER PILES REMOVED
2. EX. MOORING CLUSTER PILES REMOVED
3. PROPOSED FIXED PIER = 1,370 SF
4. PROPOSED MOORING CLUSTER PILES = 6 TOTAL

ADJACENT PROPERTIES:

1. GOVERNMENT OF DISTRICT OF COLUMBIA

NOTES: DATUM - D.C. PUBLIC WORKS

MHW EL. (+)1.65 FT

MLW EL. (-)1.14 FT

**FLORIDA ROCK
PIER REPLACEMENT**

IN: ANACOSTIA RIVER

NEAR: SOUTH CAPITOL ST. BRIDGE

APPLICATION BY:

FLORIDA ROCK PROPERTIES, INC.

34 LOVETON CIRCLE, SUITE 100

SPARKS, MD 21152



SHEET 1 OF 6

DATE: MAY 14, 2009

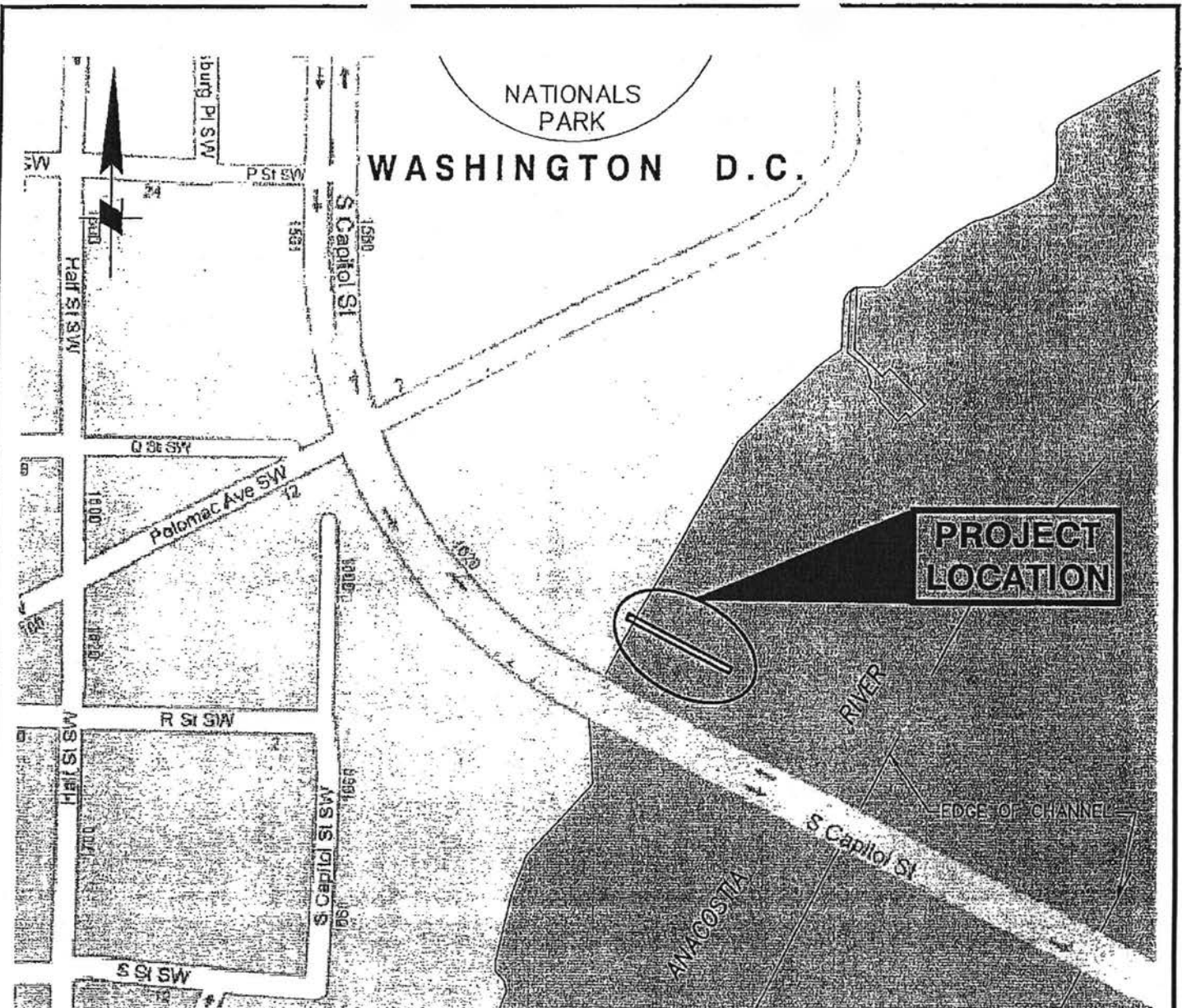

LOCATION MAP

N.T.S.

ADJACENT PROPERTIES:

1. GOVERNMENT OF DISTRICT OF COLUMBIA



**FLORIDA ROCK
PIER REPLACEMENT**

IN: ANACOSTIA RIVER
 NEAR: SOUTH CAPITOL ST. BRIDGE
 APPLICATION BY:
 FLORIDA ROCK PROPERTIES, INC.
 34 LOVETON CIRCLE, SUITE 100
 SPARKS, MD 21152

SHEET 2 OF 6 DATE: MAY 14, 2009

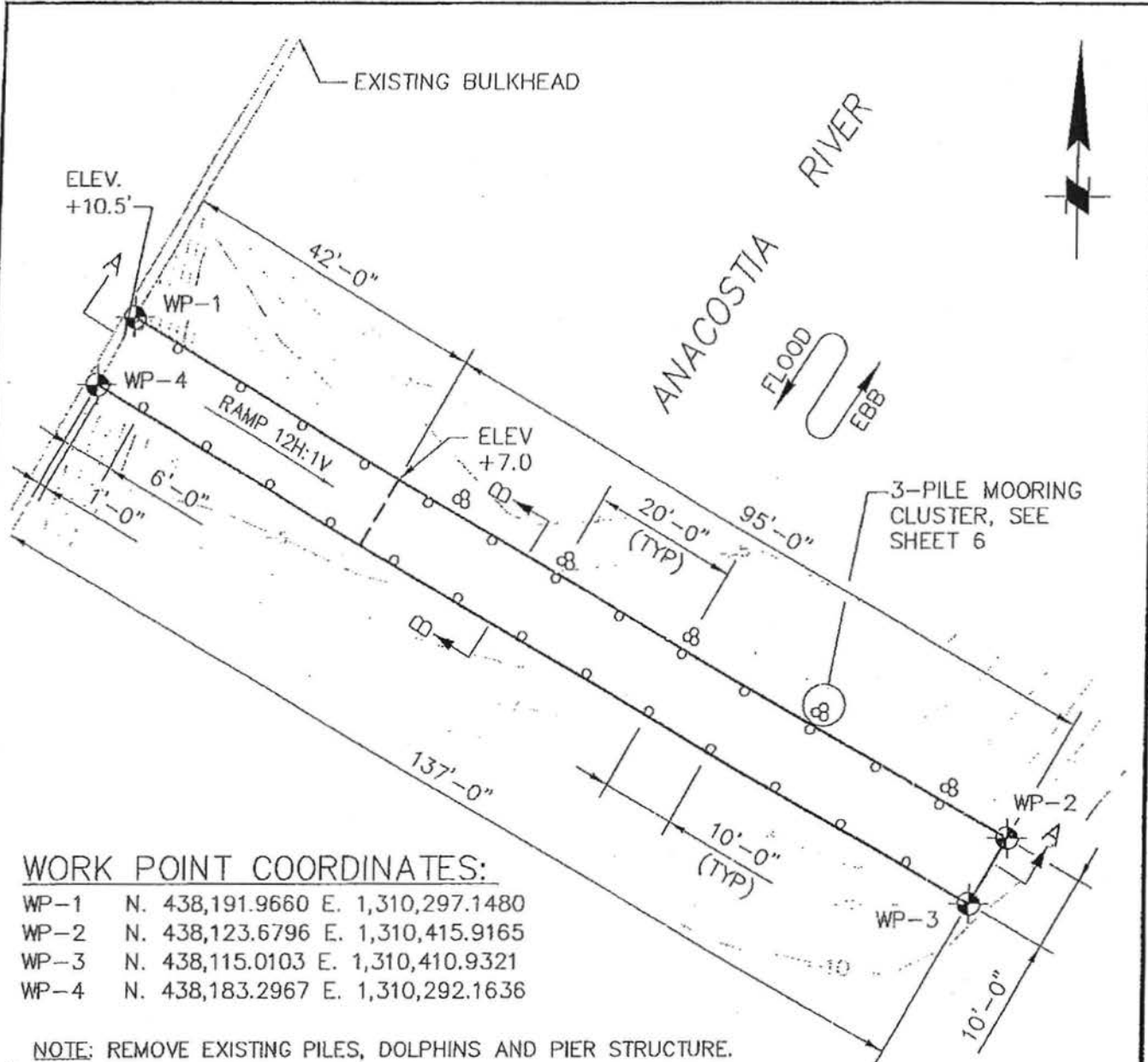

WORK POINT COORDINATES:

WP-1	N. 438,191.9660	E. 1,310,297.1480
WP-2	N. 438,123.6796	E. 1,310,415.9165
WP-3	N. 438,115.0103	E. 1,310,410.9321
WP-4	N. 438,183.2967	E. 1,310,292.1636

NOTE: REMOVE EXISTING PILES, DOLPHINS AND PIER STRUCTURE.

ADJACENT PROPERTIES:
1. GOVERNMENT OF DISTRICT OF COLUMBIA

PLAN

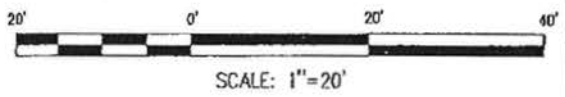

REVISED: JULY 27, 2009

**FLORIDA ROCK
PIER REPLACEMENT**

IN: ANACOSTIA RIVER
NEAR: SOUTH CAPITOL ST. BRIDGE
APPLICATION BY:
FLORIDA ROCK PROPERTIES, INC.
34 LOVETON CIRCLE, SUITE 100
SPARKS, MD 21152

SHEET 3 OF 6

DATE: MAY 14, 2009

**FREDERICK DOUGLASS
MEMORIAL BRIDGE**



P:\16894-FLORIDA ROCK\CAO\PIER PERMIT\6894OPERUID3; 27-Jul-09 11:17 AM; Drenda, Christopher

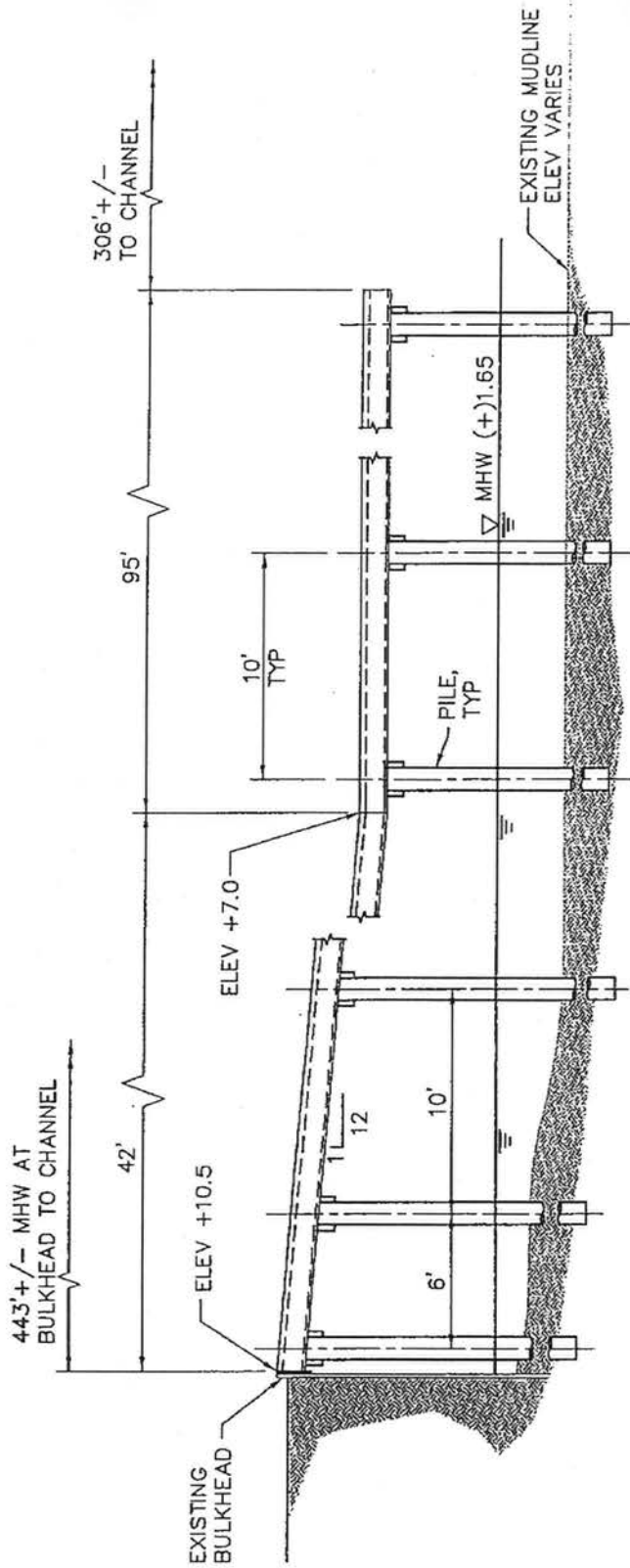

SECTION A-A
SCALE: 1/8"=1'-0"

ADJACENT PROPERTIES:

1. GOVERNMENT OF DISTRICT OF COLUMBIA



**FLORIDA ROCK
PIER REPLACEMENT**

IN: ANACOSTIA RIVER
NEAR: SOUTH CAPITOL ST. BRIDGE
APPLICATION BY:

FLORIDA ROCK PROPERTIES, INC.
34 LOVETON CIRCLE, SUITE 100
SPARKS, MD 21152

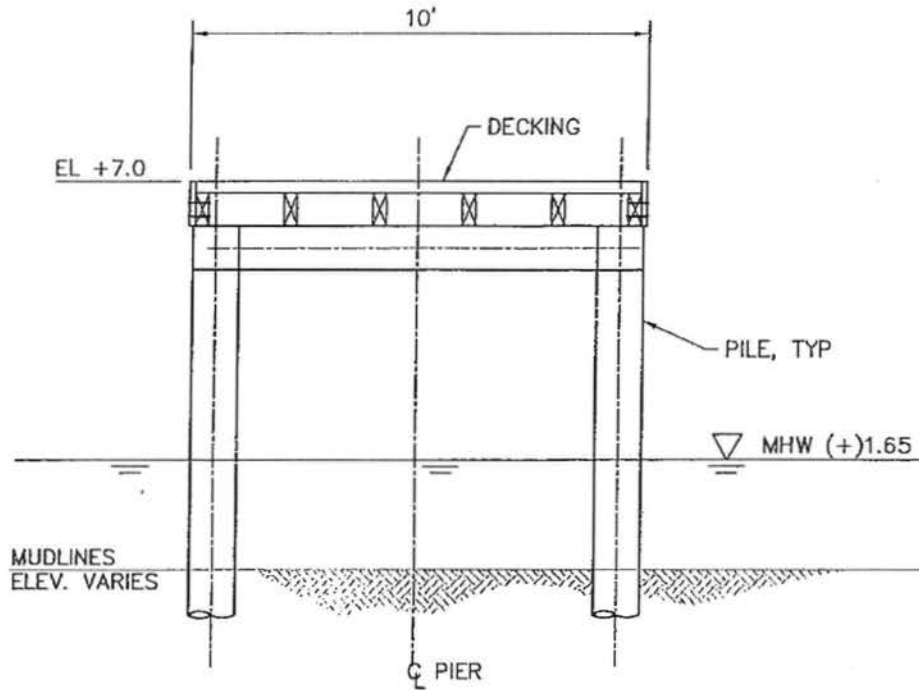

SECTION B-B

SCALE: 1/4" = 1'-0"

ADJACENT PROPERTIES:

1. GOVERNMENT OF DISTRICT OF COLUMBIA

**FLORIDA ROCK
PIER REPLACEMENT**

IN: ANACOSTIA RIVER
 NEAR: SOUTH CAPITOL ST. BRIDGE
 APPLICATION BY:
 FLORIDA ROCK PROPERTIES, INC.
 34 LOVETON CIRCLE, SUITE 100
 SPARKS, MD 21152



SHEET 5 OF 6

DATE: MAY 14, 2009

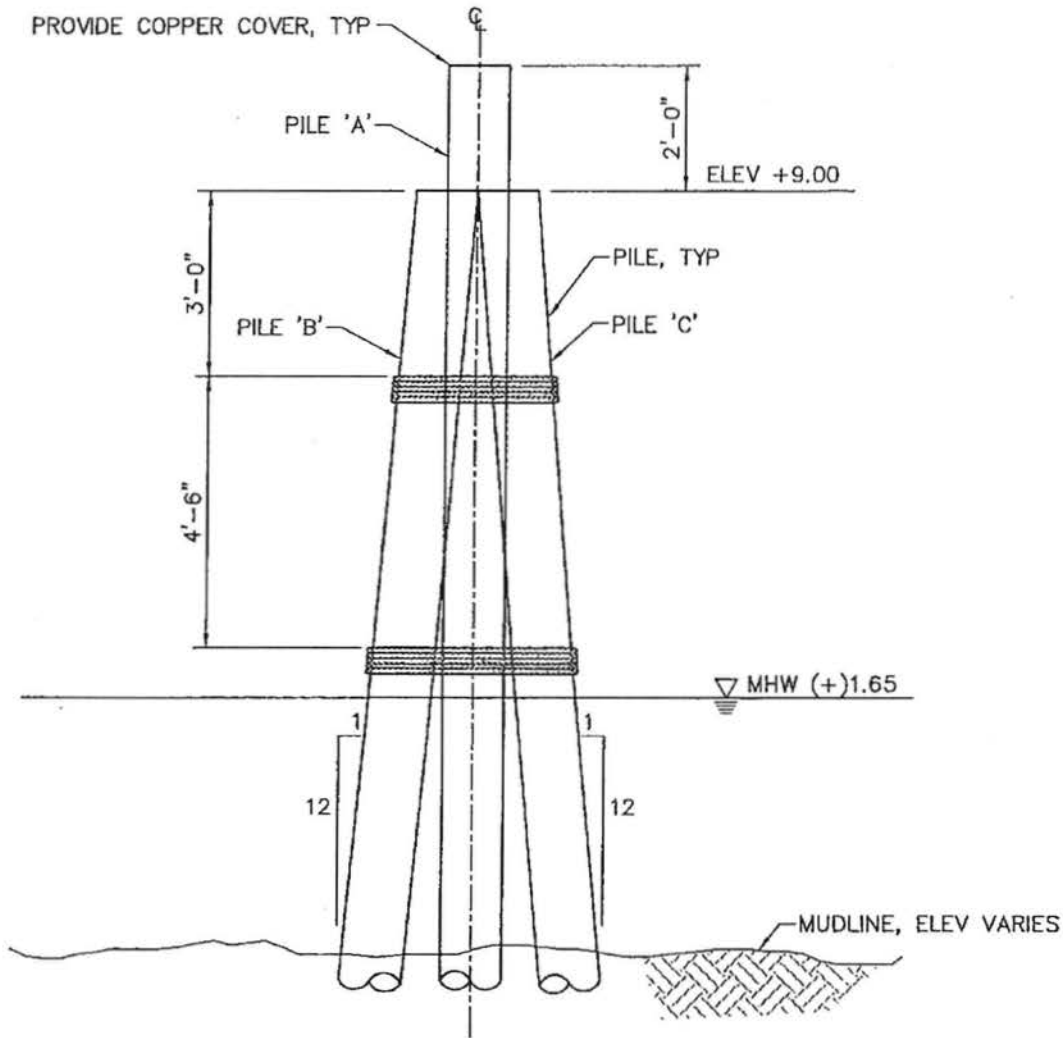
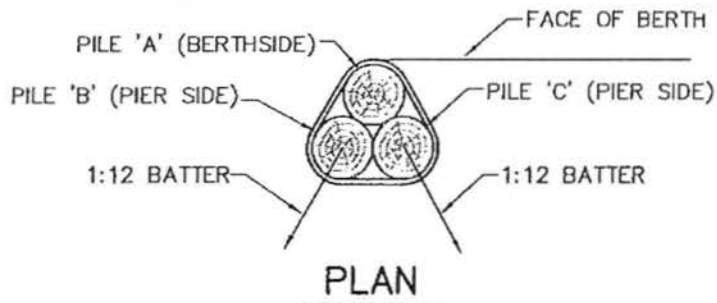

ELEVATION

3 - PILE MOORING CLUSTER 1
S3 | S6

SCALE: N.T.S.

ADJACENT PROPERTIES:

1. GOVERNMENT OF DISTRICT OF COLUMBIA



**FLORIDA ROCK
PIER REPLACEMENT**

IN: ANACOSTIA RIVER
 NEAR: SOUTH CAPITOL ST. BRIDGE
 APPLICATION BY:
 FLORIDA ROCK PROPERTIES, INC.
 34 LOVETON CIRCLE, SUITE 100
 SPARKS, MD 21152

SHEET 6 OF 6 DATE: MAY 14, 2009

P:\6894 FLORIDA ROCK\CADD\PERMIT\689400PERMIT06: 13-May-09 3:43 PM: Jay, George

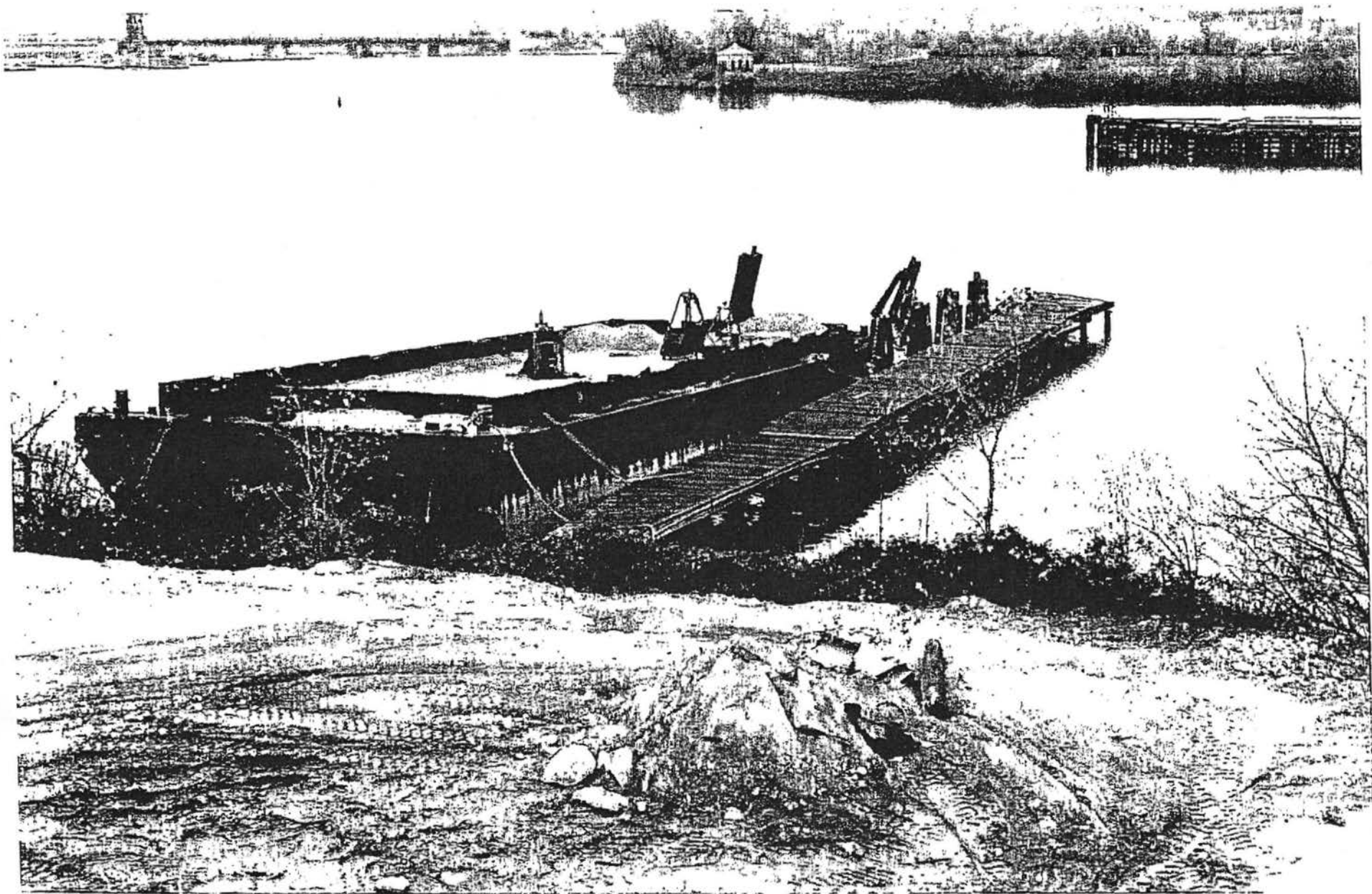

**FLORIDA ROCK PIER
1990'S**



FLORIDA ROCK PIER APRIL 2009